

Chemical Plant Monitoring Solution

G. Hanel, A. Jordan, E. Hartungen, S. Haidacher,

R. Schottkowsky, L. Märk, T. D. Märk

IONICON ANALYTIK Ges.m.b.H. Technikerstr. 21a, 6020 Innsbruck, Austria

The goal of this project was the development of a monitoring solution for dimethylsulfate in a chemical plant. This is the first approach to an absolutely new market for PTR-MS applications as a real time continuous monitoring instrument. To achieve the customers' needs it was necessary to develop a custom-tailored solution including hardware and software modifications.

Setup of the instrument :

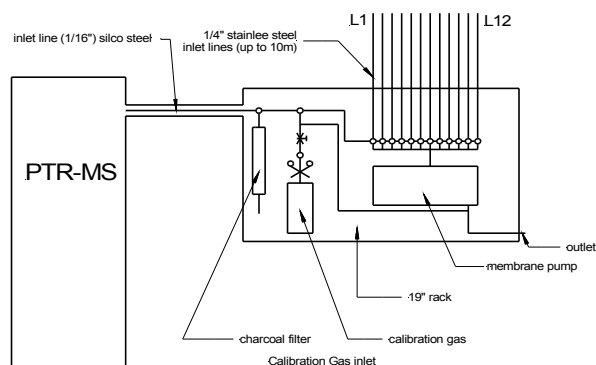

To sample the different positions twelve three way valves are used which are controlled by separate digital outputs which were added to the RS232 server build in the PTR-MS. Additional three valves are used to allow for an automatic setup and the calibration procedure. They are also controlled by the extra digital outputs.

1.) Automatic setup and optimization of the Compact PTR-MS instrument

Performance and amplification check of the channeltron

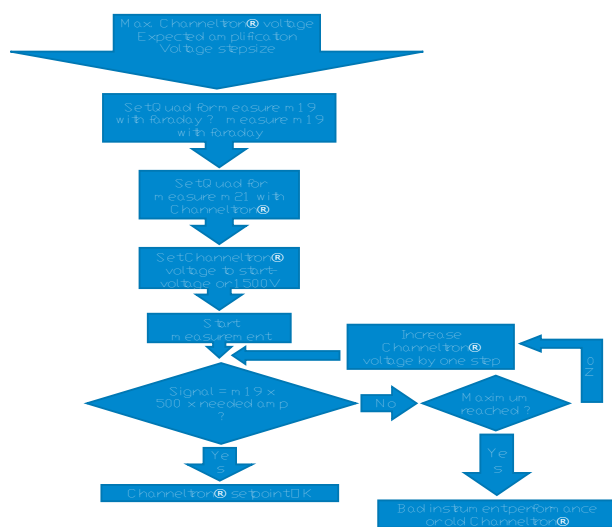

Check of the ion source stability

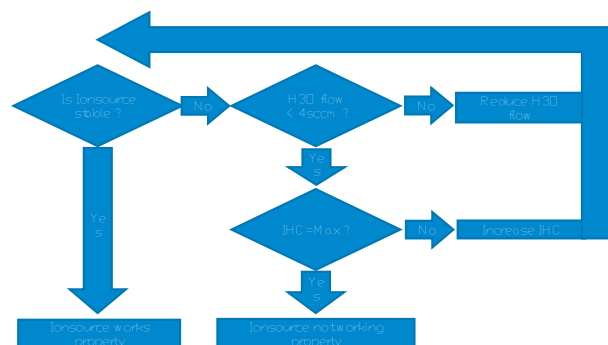

2.) Calibration of the instrument for the specific VOC (in this case dimethylsulfate)

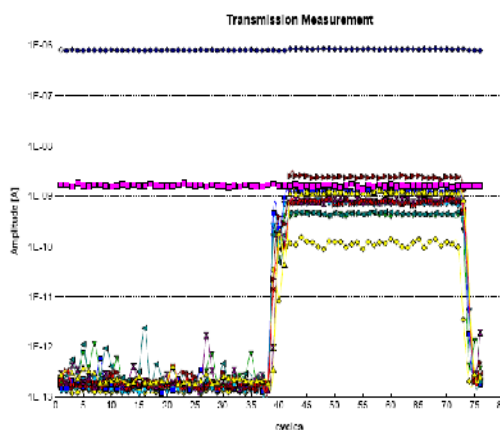

Compound	mass	Concentration
Benzene	mass 79	100 ppb
Toluene	mass 93	99,15 ppb
Styrene	mass 105	95,33 ppb
Ethylbenzene; Xylene	mass 107	384,9 ppb
Chlorobenzene	mass 113	73,86 ppb
Trimethylbenzene	mass 121	189,45 ppb
Dichlorobenzene	mass 147	164,71 ppb
Dichlorobenzene	mass 149	105,58 ppb
Trichlorobenzene	mass 181	39,18 ppb

3.) Real time sampling on twelve different points in the chemical plant

Start up of the instrument followed by optimization and by a calibration check using the built in calibration gas bottle. Earlier calibrations are compared to the current one to see if there are any significant changes in the performance which could lead to inaccurate results of the monitoring. After a successful performance check the instrument switches into the sampling mode. In this mode all twelve different points are sampled with a preset sampling time. Currently the sampling time is set to five seconds. The main monitoring screen shows a graph for each of the twelve sampling lines separately. The two alarm levels are also shown in the graph. A dimethylsulfate level higher than 5ppb gives a yellow colored alarm on the control screen. The 50ppb level gives a red colored alarm on the screen coupled to an acoustic alarm via a digital output on the instrument. The whole software to monitor this system is specifically tailored to make the operation as simple as possible. Fundamental adjustments can only be done via the password protected service mode in the software. For experienced users and for deep error checking all other PTR-MS control and the Quadstar software corresponding features are still available on the operations computer of the monitor.

